

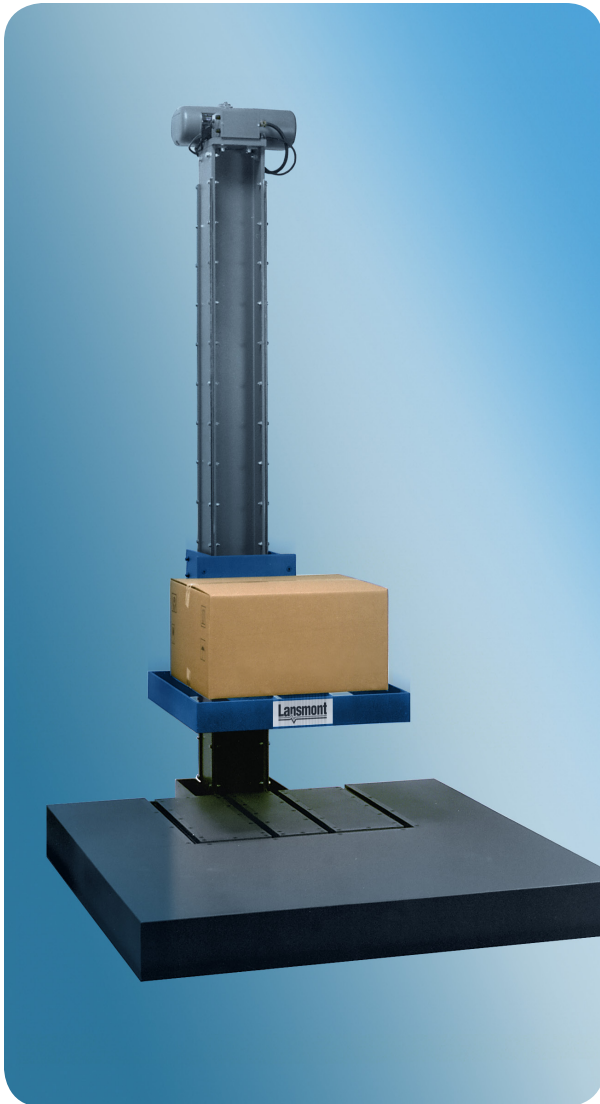

PDT 300 Precision Drop Tester



The transport and distribution environment holds numerous opportunities for packages to experience impacts and/or drops. As a result, shock is transmitted both into, and throughout, a given package. The products within the packaging respond to both the amplitude and frequency characteristics of the shock. How the various packaging components mitigate that shock determines how much shock is transmitted into the product held within. Lansmont Drop Test Systems are used to perform pre-shipment testing in an effort to design and verify cost-effective, optimized protective packaging solutions.

PERFORMANCE SPECIFICATIONS

Maximum Package Weight:

Standard carriage	661 lbs. (300 kg)
XL carriage	661 lbs. (300 kg)
XXL carriage	500 lbs. (227 kg)

Maximum Package Size (front-to-back):

Standard carriage	41.5 in. (105 cm)
XL carriage	74 in. (188 cm)
XXL carriage	118 in. (300 cm)

Drop Height Range:

Standard carriage	1 - 72 in. (2.5 - 183 cm)*
XL carriage	1 - 72 in. (2.5 - 183 cm)
XXL carriage	1 - 72 in. (2.5 - 183 cm)

* Extended drop height available.

FLATNESS ACCURACY

Before each drop tester is shipped, its accuracy is verified to within +/- 2 degrees.

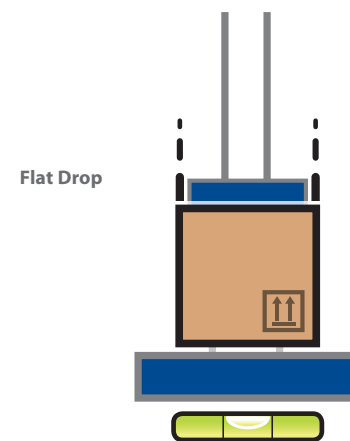



PDT 300 Precision Drop Tester



FEATURES



Handheld Controller:

The rugged handheld controller provides all necessary functionality for using Lansmont's Precision Drop Test Systems. The user can select the desired drop height via the controller and the machine will automatically move the drop platen to this height setting. No tape measure or manual adjustment is needed. All important information about the drop tester or the current settings is easily read on the LED screen on the front of the controller pendant.

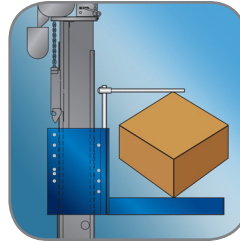

Edge and Corner Holding Fixture:

An Edge and Corner Holding fixture is included to assist with orienting large, bulky packages for testing. Oversized or custom E&C fixtures are available for special drop testing applications.



Electric Hoist:

Moving large packages by hand can be a pain. When positioning heavy and cumbersome packages during drop testing, the electric hoist positioning system does all the heavy lifting.

OPTIONS

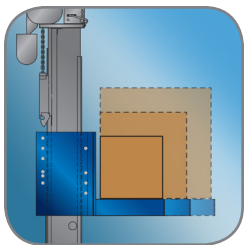

Extended Carriages:

To accommodate testing of larger packages, drop carriages with extended length are available that may be better suited to your largest package size.



Steel Baseplates:

Steel Baseplates are available for the standard and extended carriage sizes. Baseplate dimensions vary depending on carriage size and impact area.



Test Partner Data Acquisition:

Lansmont's Test Partner sets the standard for data acquisition systems used for laboratory impact testing. Test Partner is a powerful combination of software and hardware specifically tailored to capture and analyze mechanical shock, drop, and impact events. It can acquire up to sixteen channels of acceleration data simultaneously.



PDT 300 Precision Drop Tester



SIZES

STEEL BASE OPTIONS			
Carriage	Length (A)	Impact Area (W1 x D1)	Overall Dimensions (W2 x D2)
Standard	27.7 in. (70 cm)	60 in. wide x 41.5 in. deep (152 cm x 105 cm)	64 in. wide x 60 in. deep (163 cm x 152 cm)
XL	40 in. (102 cm)	74 in. wide x 60 in. deep (188 cm x 152 cm) 84 in. wide x 78.8 in. deep (213 cm x 200 cm)	78 in. wide x 78.5 in. deep (198 cm x 199 cm) 88 in. wide x 97.3 in. deep (224 cm x 247 cm)
XXL	60 in. (152 cm)	84 in. wide x 78.8 in. deep (213 cm x 200 cm) 118 in. wide x 118 in. deep (300 cm x 300 cm)	88 in. wide x 97.3 in. deep (224 cm x 247 cm) 122 in. wide x 136.5 in. deep (310 cm x 347 cm)

CARRIAGE

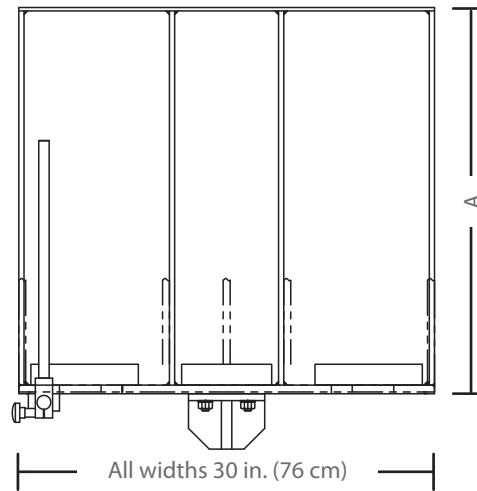

STEEL BASE

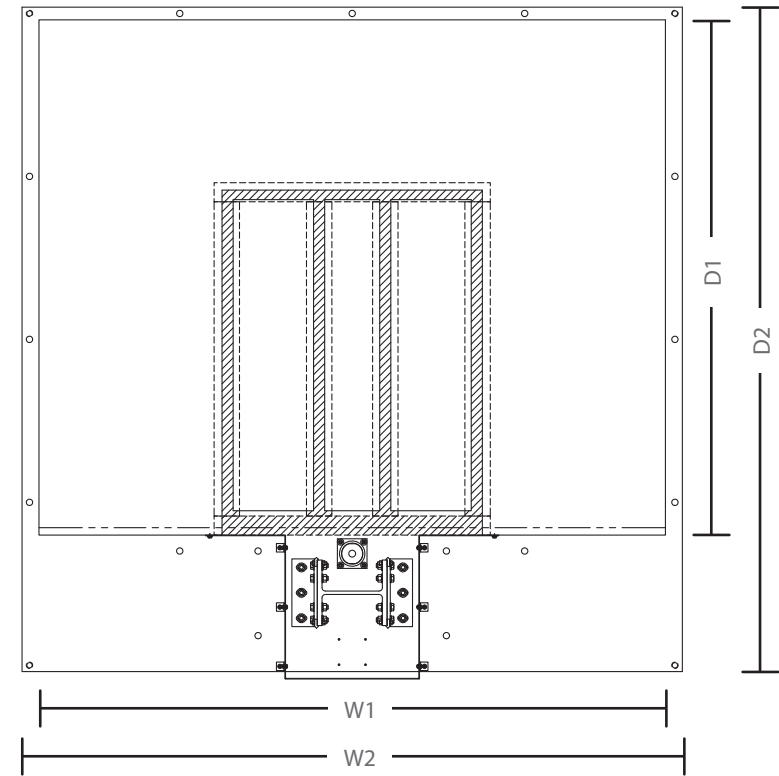

MADE TO ORDER

Not quite the equipment size or performance level that you need? If we do not already manufacture the test machine ideally suited for your company's testing applications, our engineering team can custom design a test system specific to your needs.

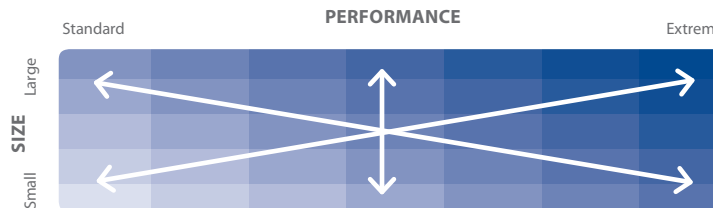



PDT 300 Precision Drop Tester



SPECIFICATIONS

UTILITIES

Power -

Standard voltages:	110 VAC - 1 phase - 60 Hz. (10 amps)	220 VAC - 1 phase - 50 Hz. (5 amps)
Optional voltages:	100 VAC - 1 phase - 50 Hz. (10 amps)	200 VAC - 1 phase - 50 Hz. (5 amps)
	100 VAC - 1 phase - 60 Hz. (10 amps)	220 VAC - 1 phase - 60 Hz. (5 amps)
		200 VAC - 1 phase - 60 Hz. (5 amps)

Plant Air -

Pressure:	40 - 60 psi (2.7 - 4.1 ATM)
Flow Rate:	0.5 scfm

MACHINE DIMENSIONS (standard configuration)

Height:	Base Width:	Base Length:
114.25 in. (290 cm)	64 in. (163 cm)	60 in. (152 cm)

CRATE INFORMATION (standard configuration)

	Height:	Width:	Length:	Shipping Weight:
With Steel Base (1 crate)	50 in. (127 cm)	89 in. (226 cm)	130 in. (330 cm)	7500 lbs. (3401 kg)
With Foundation Base (3 crates)				
I-Beam	29 in. (73.7 cm)	26 in. (66 cm)	120 in. (304 cm)	900 lbs. (408 kg)
Carriage	36 in. (91 cm)	54 in. (137 cm)	40 in. (102 cm)	700 lbs. (318 kg)
Forms	18 in. (45.7 cm)	40 in. (102 cm)	55 in. (140 cm)	330 lbs. (150 kg)

SYSTEM DRAWINGS (standard configuration)

SIDE VIEW

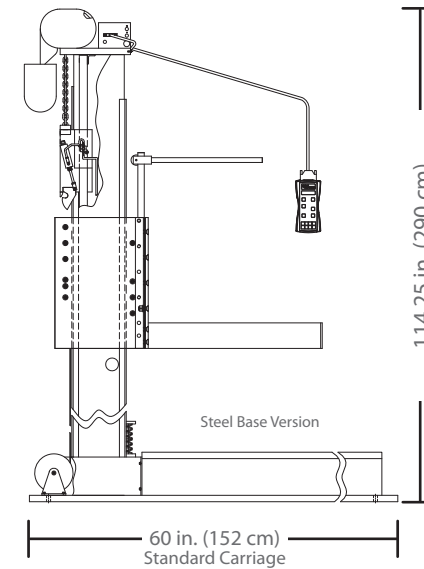

FRONT VIEW

